

8 7 6 5 4 3 2 1

F
E
D
C
B
A

F
E
D
C
B
A

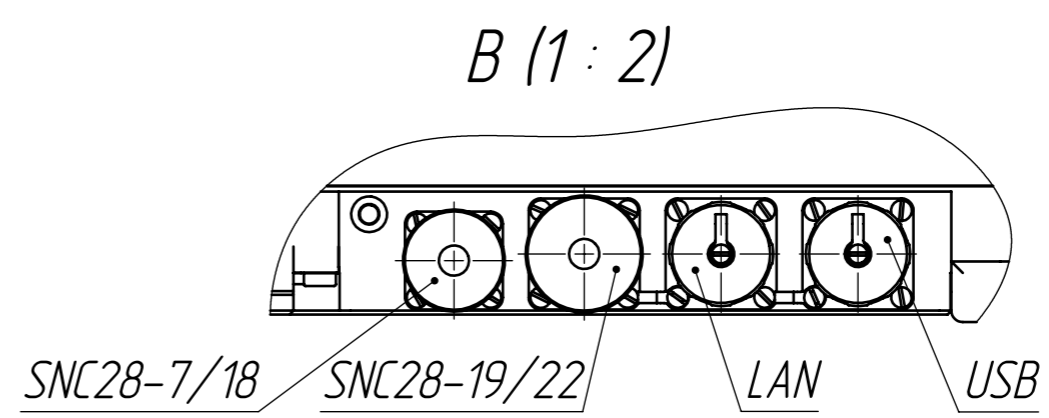
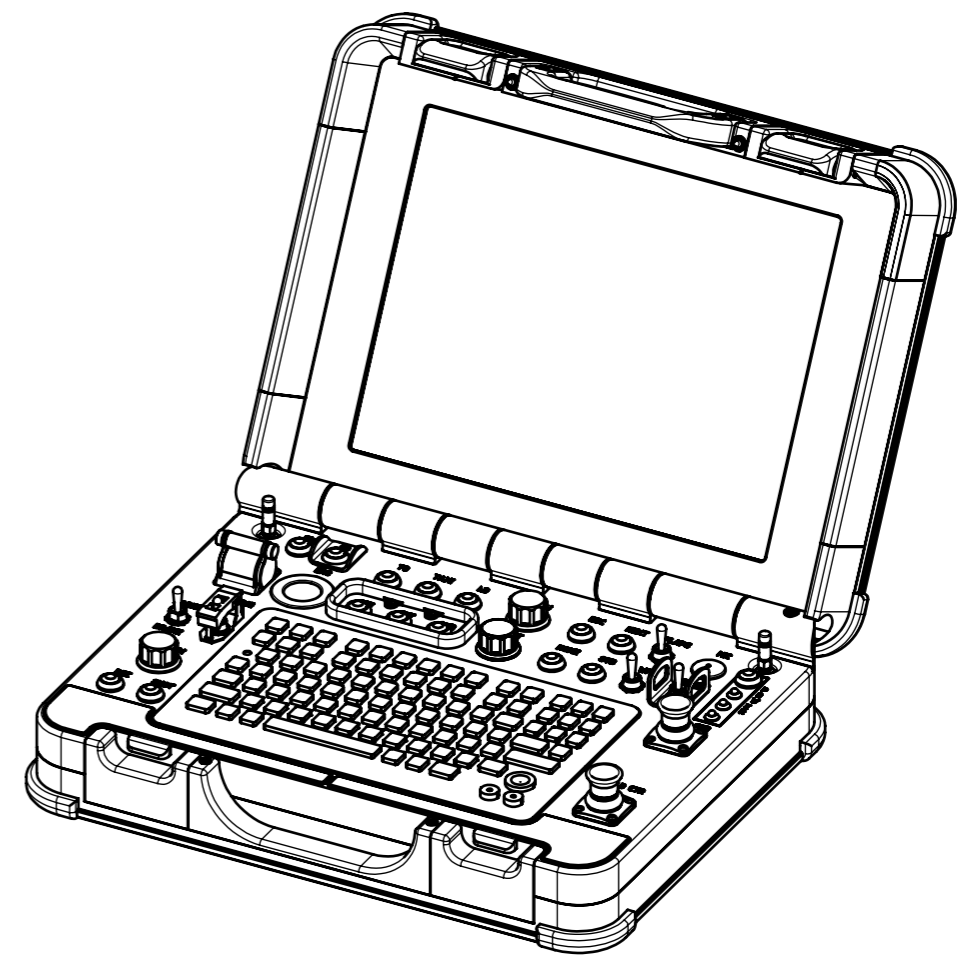
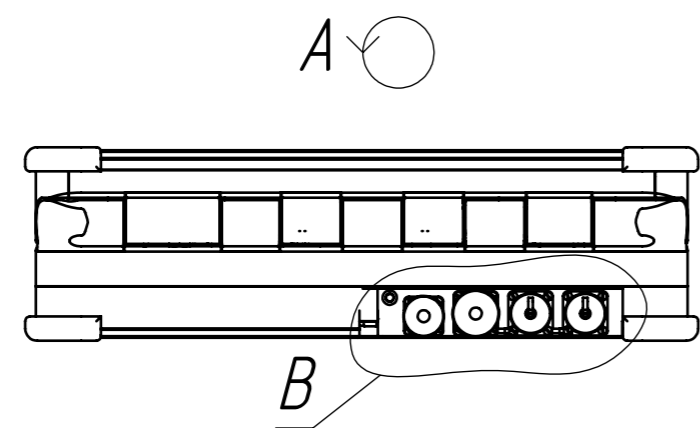
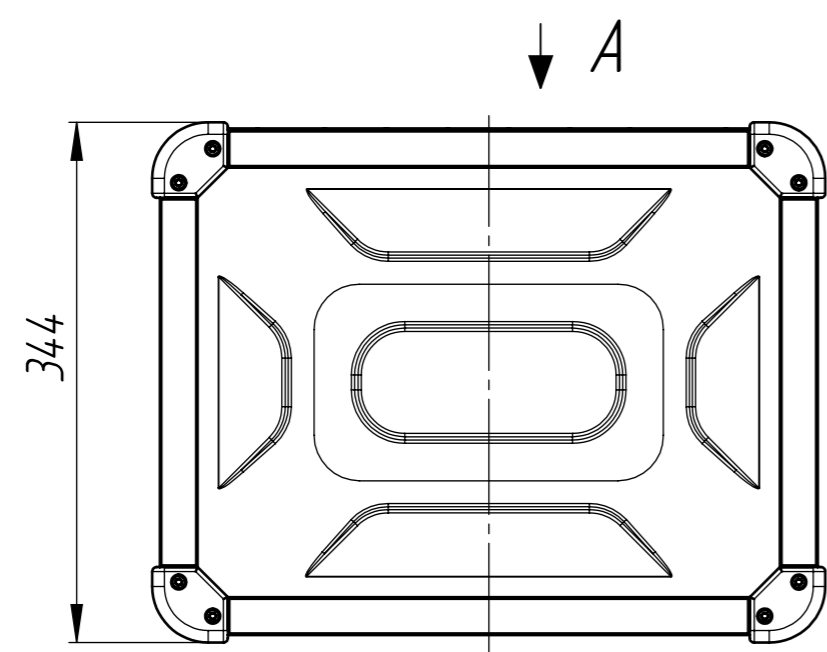
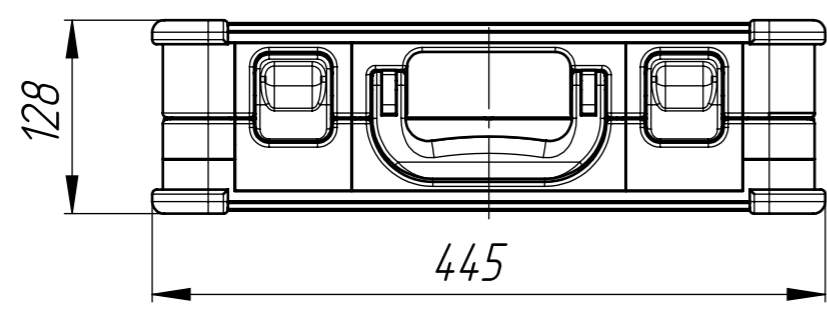

This drawing and any information or descriptive material set out on it are the confidential and copyright property of UAVOS © and MUST NOT BE DISCLOSED, COPIED, LOANED in whole or part or used for any purpose without the written permission of UAVOS.

NEXT ASSY	USED ON
APPLICATION	

UNLESS OTHERWISE SPECIFIED
DIM ARE IN MILLIMETERS
[DIM ARE IN INCHES]
TOL ON ANGLES $\pm 0.5^\circ$
0 PLACE ± 0.5 1 PLACE ± 0.1
INTERPRET DIM AND TOL
PER ASME Y14.5M
Surface Finish: $Ra3.2$

THIRD ANGLE PROJECTION

DRAFTER	
CHECKER	
DEV ENGR	
CONTRACT NO.	
UAVOS FUNDED	
MATERIAL	

UAVOS Inc.
Unmanned Systems - Redwood, CA USA

Portable ground control unit mini (PGCUM)

SIZE A3	CAGE CODE	DRAWING NUMBER UV01.468323.04	REV 1
SCALE 1:5	WEIGHT KG 11.2	SHEET 1 OF 2	

8 7 6 5 4 3 2 1

12 11 10 9 8 7 6 5 4 3 2 1

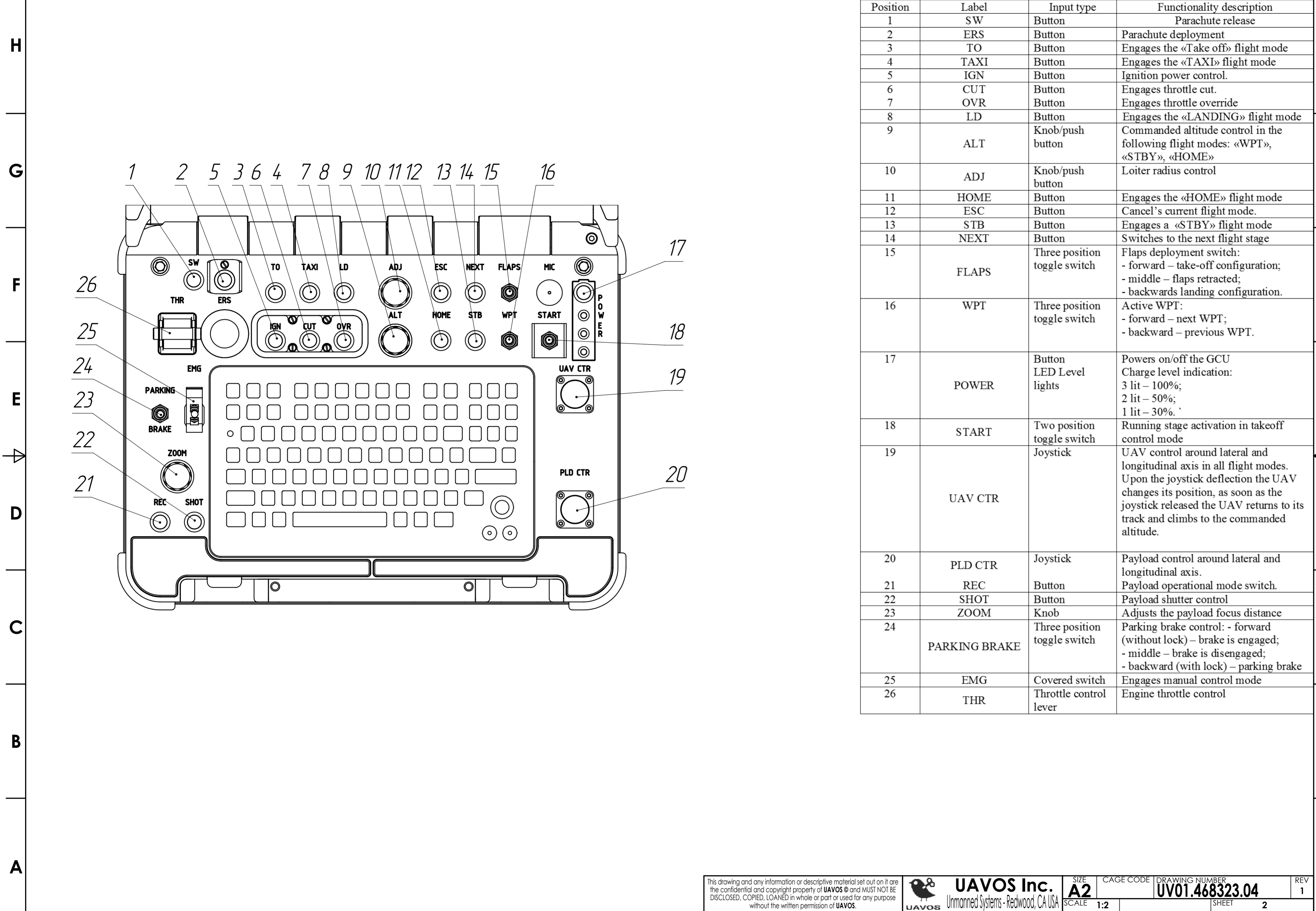

Position	Label	Input type	Functionality description
1	SW	Button	Parachute release
2	ERS	Button	Parachute deployment
3	TO	Button	Engages the «Take off» flight mode
4	TAXI	Button	Engages the «TAXI» flight mode
5	IGN	Button	Ignition power control.
6	CUT	Button	Engages throttle cut.
7	OVR	Button	Engages throttle override
8	LD	Button	Engages the «LANDING» flight mode
9	ALT	Knob/push button	Commanded altitude control in the following flight modes: «WPT», «STBY», «HOME»
10	ADJ	Knob/push button	Loiter radius control
11	HOME	Button	Engages the «HOME» flight mode
12	ESC	Button	Cancel's current flight mode.
13	STB	Button	Engages a «STBY» flight mode
14	NEXT	Button	Switches to the next flight stage
15	FLAPS	Three position toggle switch	Flaps deployment switch: - forward – take-off configuration; - middle – flaps retracted; - backwards landing configuration.
16	WPT	Three position toggle switch	Active WPT: - forward – next WPT; - backward – previous WPT.
17	POWER	Button LED Level lights	Powers on/off the GCU Charge level indication: 3 lit – 100%; 2 lit – 50%; 1 lit – 30%.
18	START	Two position toggle switch	Running stage activation in takeoff control mode
19	UAV CTR	Joystick	UAV control around lateral and longitudinal axis in all flight modes. Upon the joystick deflection the UAV changes its position, as soon as the joystick released the UAV returns to its track and climbs to the commanded altitude.
20	PLD CTR	Joystick	Payload control around lateral and longitudinal axis.
21	REC	Button	Payload operational mode switch.
22	SHOT	Button	Payload shutter control
23	ZOOM	Knob	Adjusts the payload focus distance
24	PARKING BRAKE	Three position toggle switch	Parking brake control: - forward (without lock) – brake is engaged; - middle – brake is disengaged; - backward (with lock) – parking brake
25	EMG	Covered switch	Engages manual control mode
26	THR	Throttle control lever	Engine throttle control

12 11 10 9 8 7 6 5 4 3 2 1