

16 15 14 13 12 11 10 9 8 7 6 5 4 3 2 1

M L K J H G F E D C B A

REVISIONS			
REV	DESCRIPTION	DATE	APPROVED

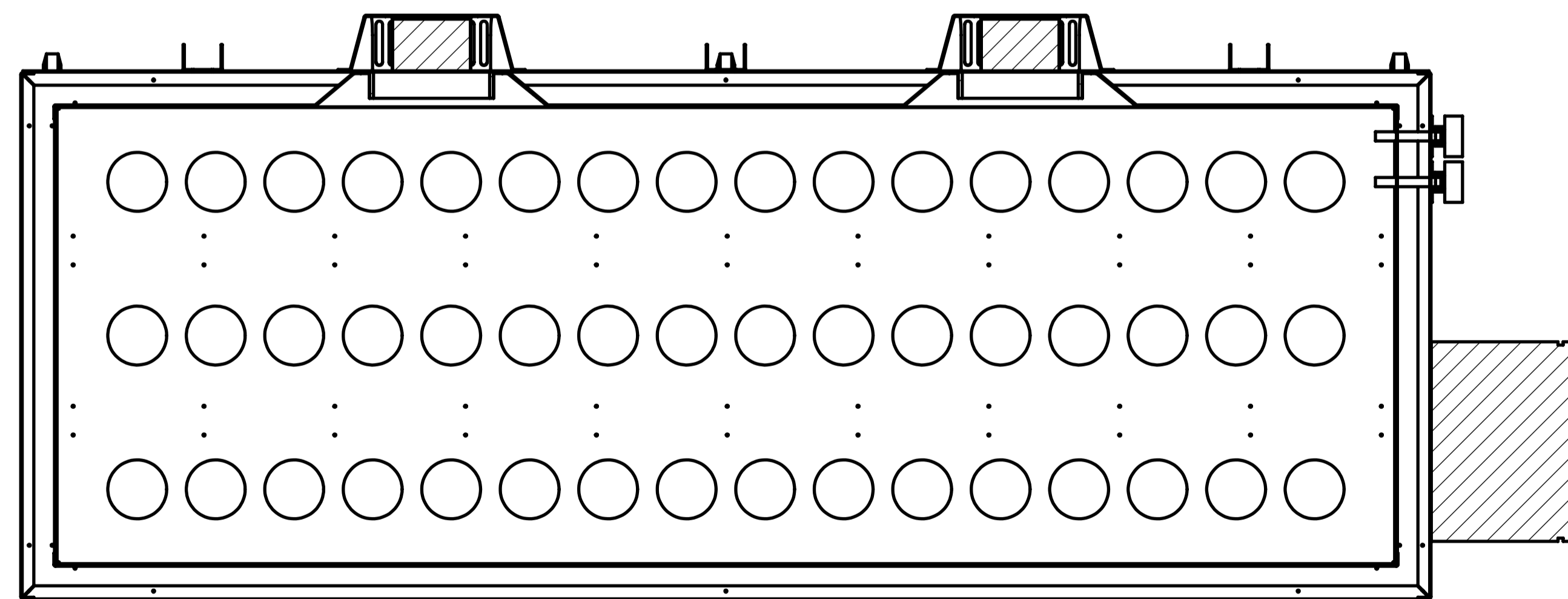
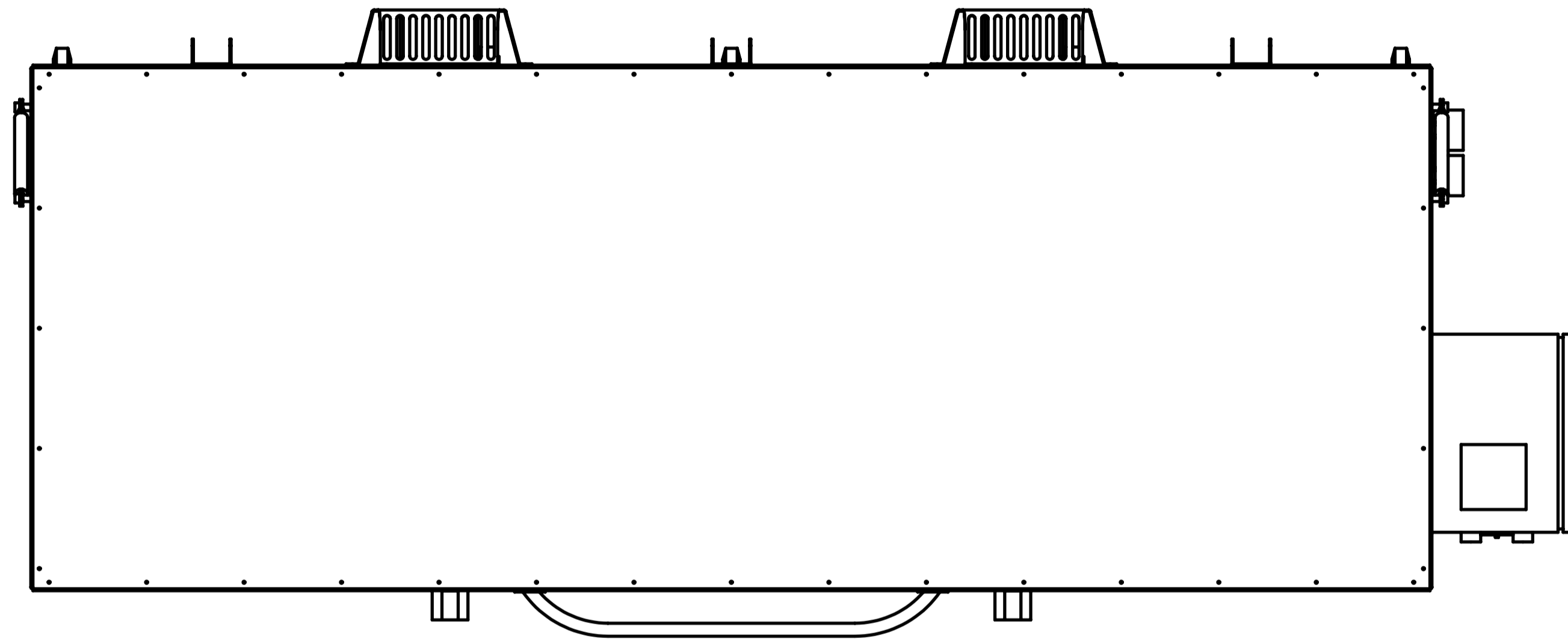
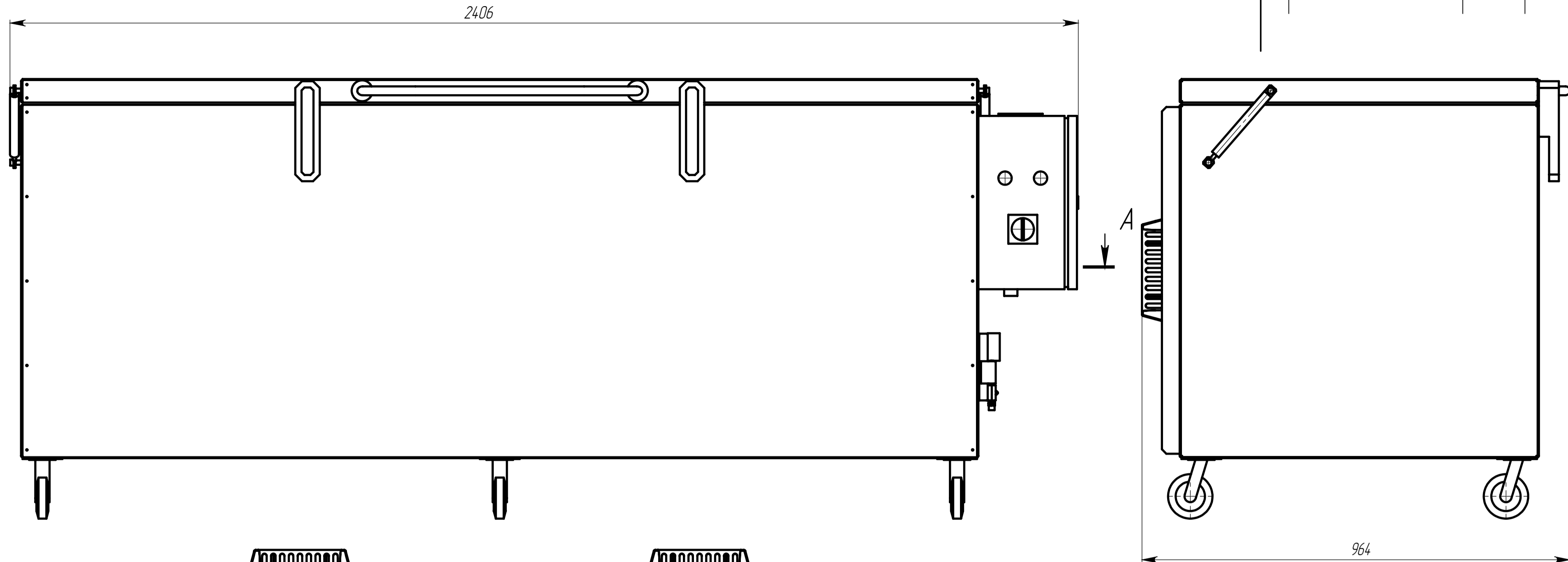
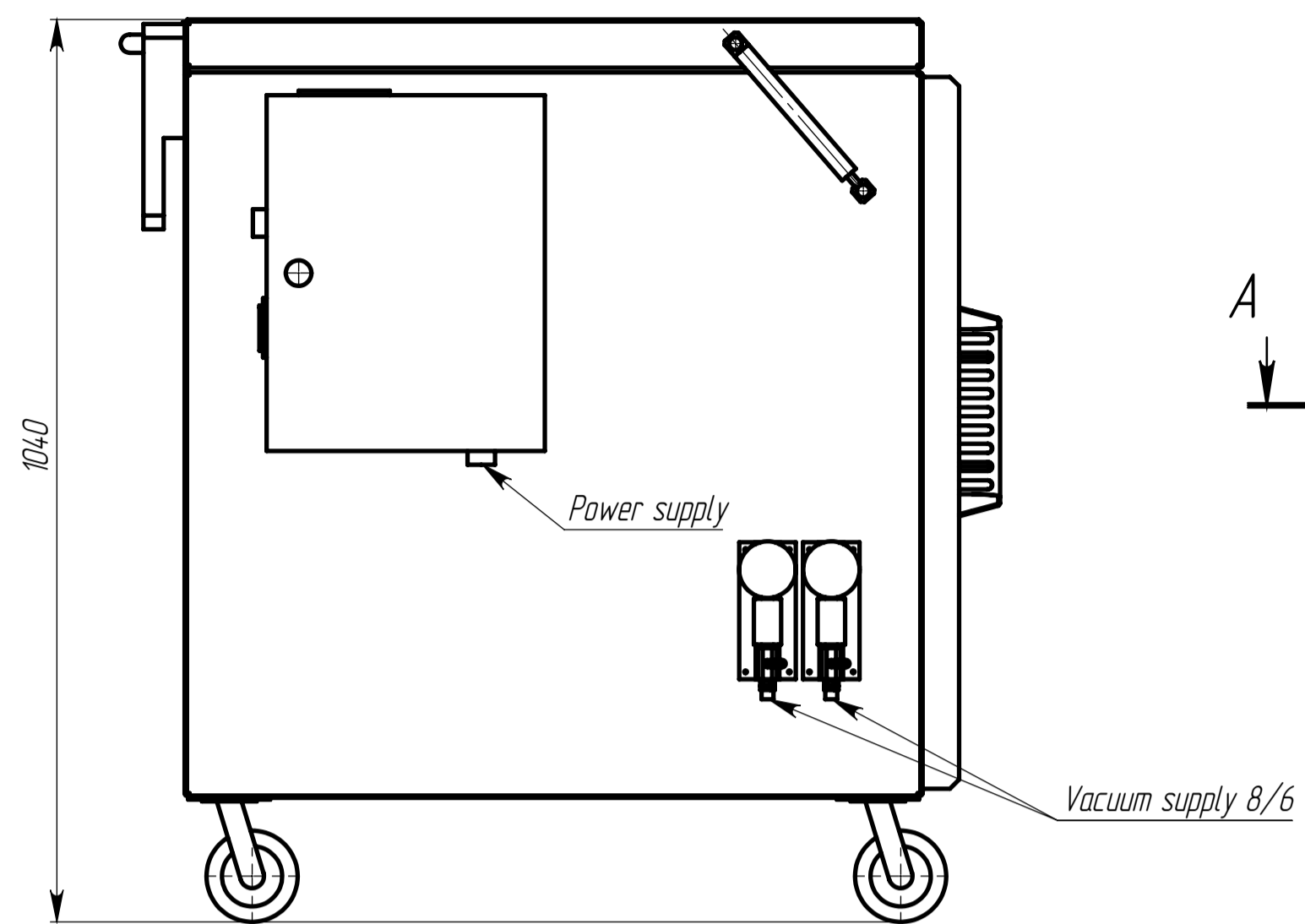

Inner dimensions:  
height 728 mm (704 mm with shelf) x width 702 mm x length 2050 mm

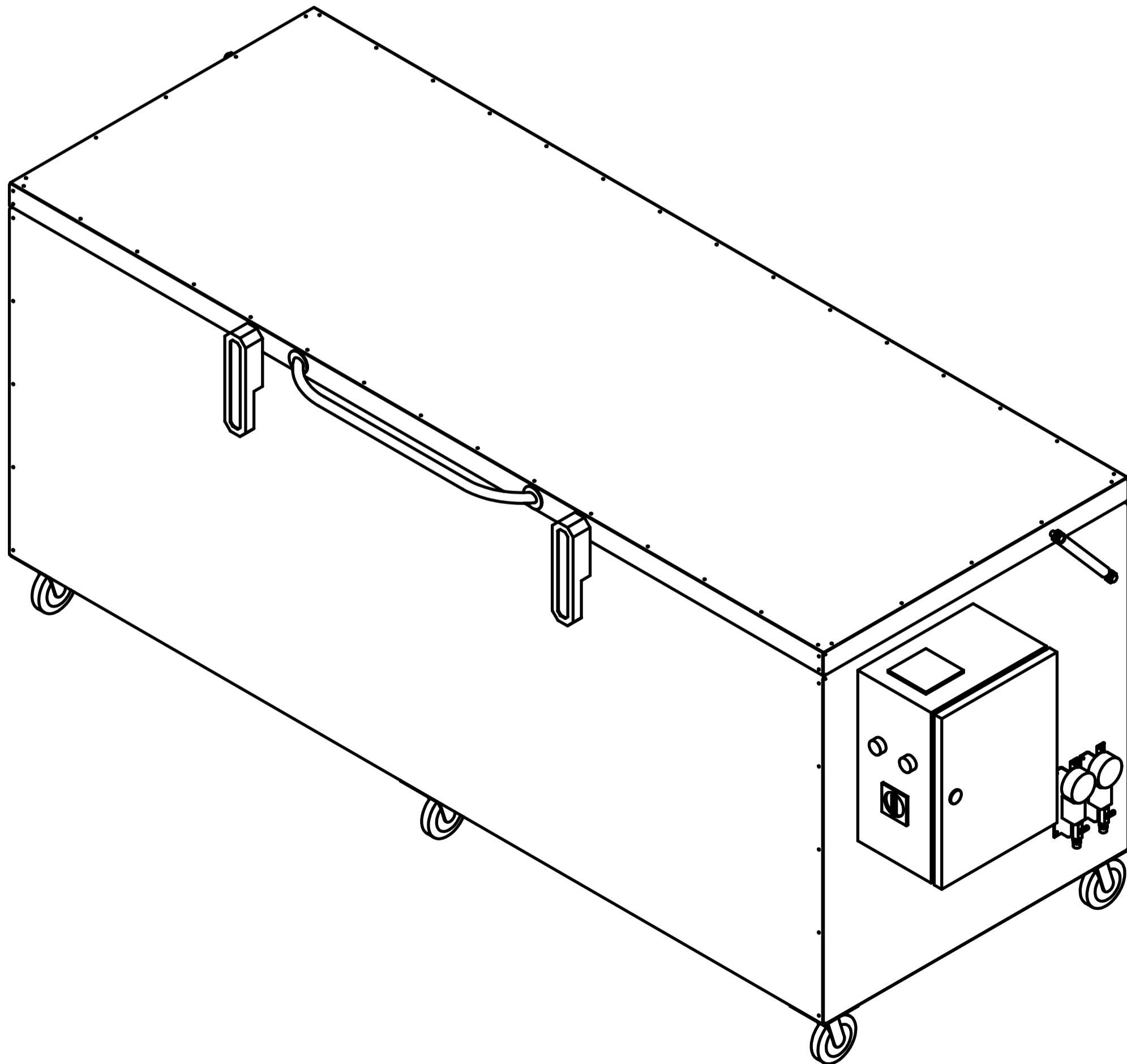

This drawing and any information or descriptive material set out on it are the confidential and copyright property of UAVOS® and MUST NOT BE DISCLOSED, COPIED, LOANED in whole or part or used for any purpose without the written permission of UAVOS.

UNLESS OTHERWISE SPECIFIED  
DIM ARE IN MILLIMETERS  
[DIM ARE IN INCHES]  
TOL ON ANGLES  $-0.5^\circ$   
0 PLACE  $\pm 0.5$  1 PLACE  $\pm 0.1$   
INTERPRET DIM AND TOL  
PER ASME Y14.5M  
Surface Finish:  $Ra3.2$

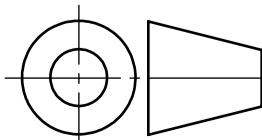

DRAFTER  
CHECKER  
DEV ENGR

CONTRACT NO.  
UAVOS FUNDED

MATERIAL



**UAVOS**

**OV 700**

SIZE <b>A1</b>	CAGE CODE	DRAWING NUMBER	REV 10
SCALE 1:7	WEIGHT KG	SHEET	1 OF 1

16 15 14 13 12 11 10 9 8 7 6 5 4 3 2 1