

12 11 10 9 8 7 6 5 4 3 2 1

REVISIONS			
REV	DESCRIPTION	DATE	APPROVED

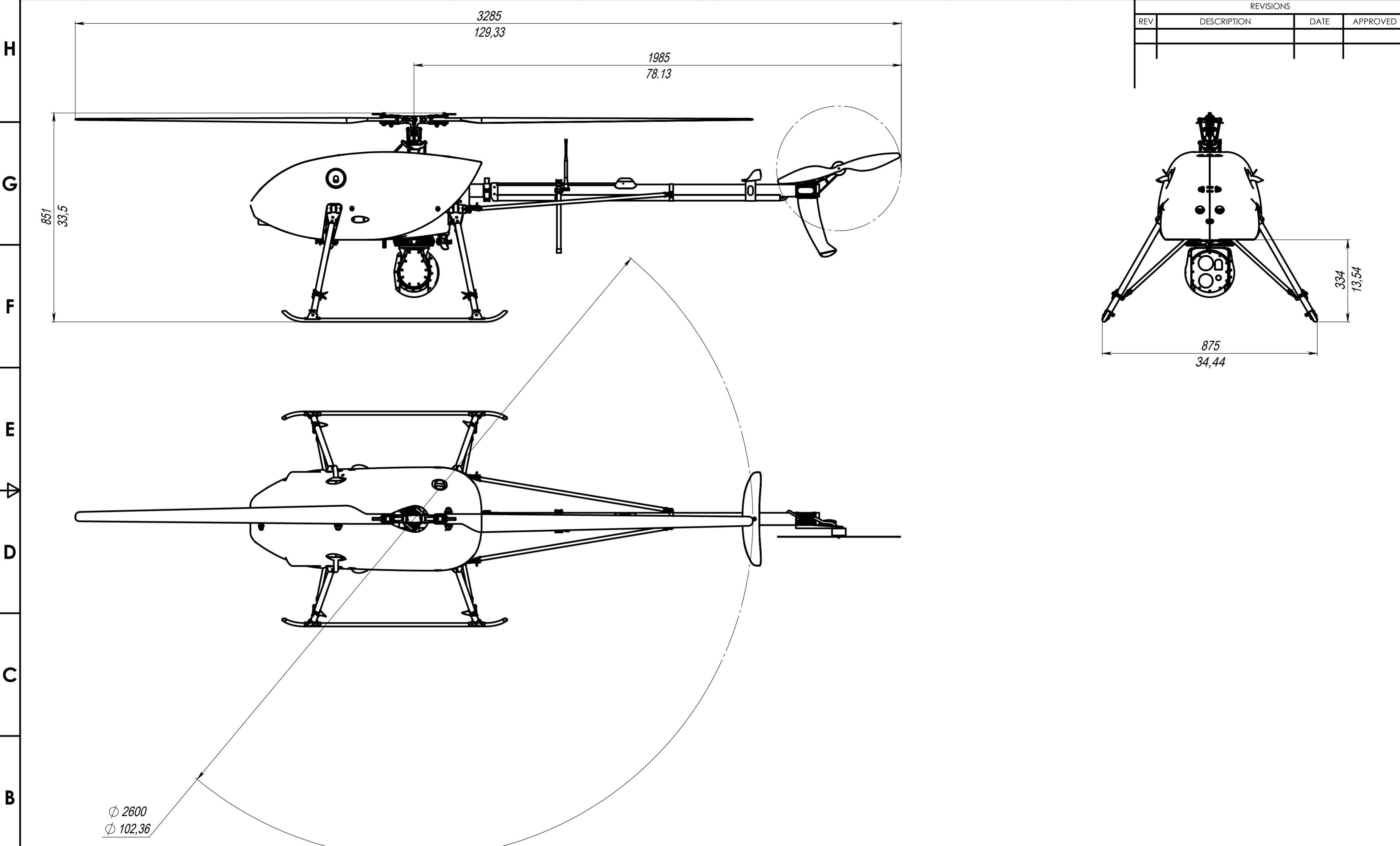

This drawing and any information or descriptive material set out on it are the confidential and copyright property of **UAVOS**® and MUST NOT BE DISCLOSED, COPIED, LOANED in whole or part or used for any purpose without the written permission of **UAVOS**.

NEXT ASSY	USED ON
APPLICATION	

UNLESS OTHERWISE SPECIFIED
DIM ARE IN MILLIMETERS
[DIM ARE IN INCHES]
TOL ON ANGLES $\pm 0.5^\circ$
0 PLACE ± 0.5 1 PLACE ± 0.1
INTERPRET DIM AND TOL
PER **ASME Y14.5M**
Surface Finish: **Ra3.2**

THIRD ANGLE PROJECTION

DRAFTER	
CHECKER	
DEV ENGR	
CONTRACT NO.	
UAVOS FUNDED	
MATERIAL	

UAVOS

TITLE

UVH 170

SIZE	CAGE CODE	DRAWING NUMBER	REV
A2		UV01.6401.06.00.00	10
SCALE	WEIGHT KG	SHEET	1 OF 1
1:10			

12 11 10 9 8 7 6 5 4 3 2 1