

# Servo-drive SD-01B-XX-XXX

## Technical Specification

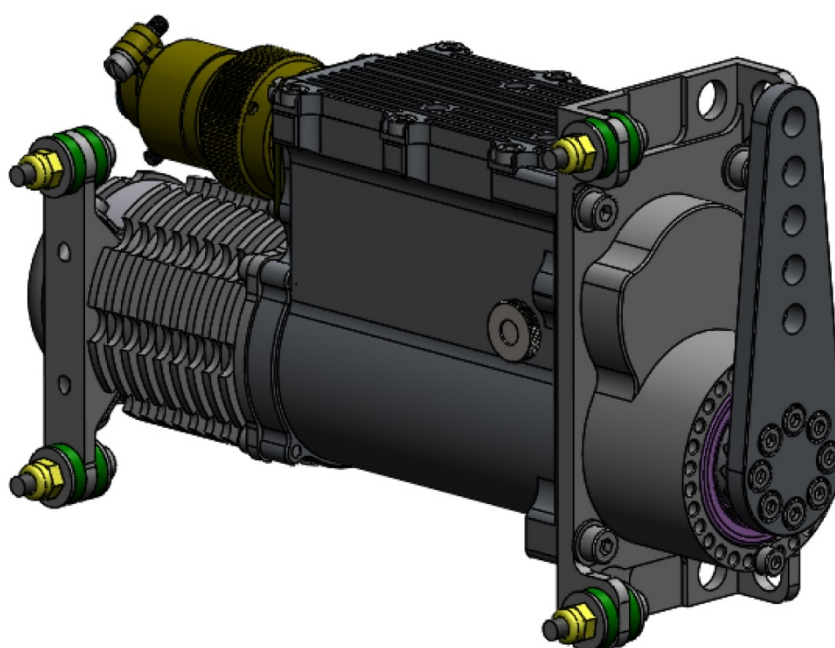
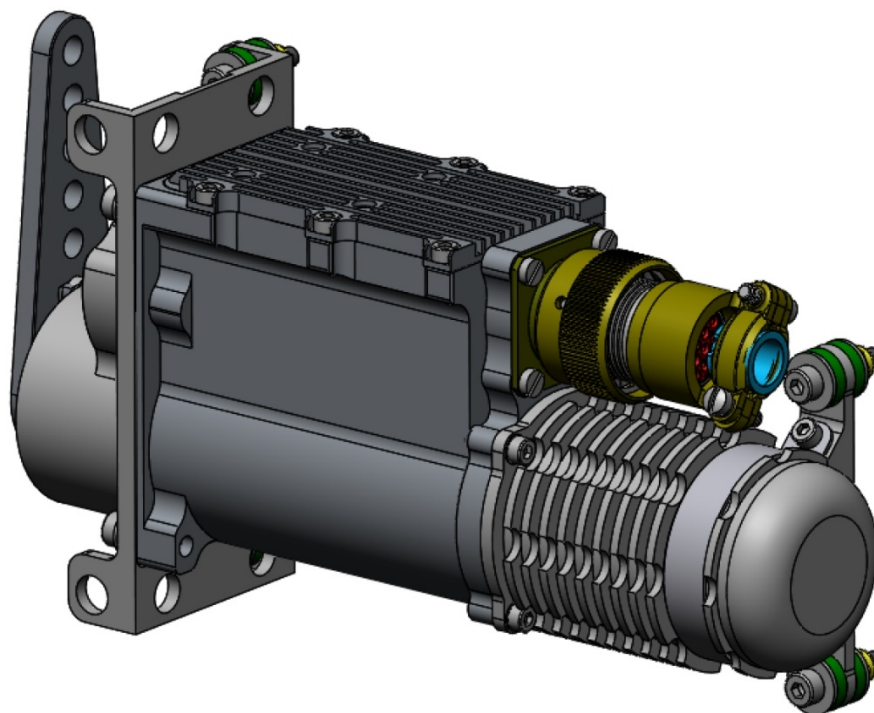

## TECHNICAL DESCRIPTION

### 1 SD-01B-XX-XXX [UV01.654116.10]

Rugged and durable rotating type servo for professional intensive applications.

#### 1.1 Application:

- Conversion of manned aircraft into UAV
- Equipping of manned aircraft with automatic piloting system (APS)
- Power movement of UAV control surfaces and elements
- Other types of unmanned vehicles

#### 1.2 Technical specification:

- Connector type: PT02E-14-12P (12-pins) (matching plug: PT06E-14-12S)  
Option type connector: PT02E-12-4P (4-pins) (matching plug: PT06E-12-4S)
- Anodized aluminum.
- Fixing type: intermediate bracket

##### Features:

- Brushless motor BLDC & FOC (Field Oriented Control)
- Two contactless encoders for dual-loop control
- Built in shunt resistor for regenerative braking (on request). The current version w/o shunt. **If shunt embedded, then upper voltage range must be 2-3 V less than current register 'Shunt enable voltage' value !!!** If the input voltage exceeds the value in the register 'Shunt enable voltage' the servo actuator will be damaged !!! Default value 'Shunt enable voltage' 42 VDC.
- Reverse polarity protection (on request). **Attention: the current version is not protected against damage due to polarity reversal !!! Observe the polarity of the connection !!!**

##### Main feedback data from servo-drive:

- Actual position, actual velocity
- Bus voltage, active motor current
- Power stage & BLDC motor temperature
- Humidity control inside the case

### 1.3 Operational data:

Specification	SD-01B-24-108 UV01.654116.08.10
Rated voltage	24 VDC
Absolute supply voltage range (min. – max.)	9 – 75 VDC
Recommended power supply voltage range <sup>1</sup>	12 VDC – 40 VDC
Standby Current at rated voltage	0.12 A
Rated Current at rated voltage	6.4 A
Peak Current at rated voltage	10.1 A
Rated Continuous Torque at rated speed <sup>2</sup>	15.5 Nm
Intermittent torque <sup>3</sup>	20 Nm
Peak Torque at rated voltage <sup>4</sup>	25 Nm
Rated Speed at rated torque	454 deg/s
Default Travel Angle	No Default Travel Angle
Max. Travel Angle	≤ 360°
Backlash (mechanical)	≤ 0,4°
Position Error under Temperature	≤ 0,1°
Operating Temperature Range	-40°C ... +85°C (-40°F ... +185°F)
Storage Temperature Range	-40°C ... +90°C (-40°F ... +194°F)
Weight (including match connector)	1500 g (52.9 oz) ±10%
IP Ratings (Ingress Protection)	IP65
Size	195 mm x 108 mm x 50 mm
Control interface	RS485 (ICD); CANopen; EtherCAT; CAN (proprietary)

<sup>1</sup> This voltage range ensures a safety margin including power supply tolerances and regulation during acceleration and deceleration. **If shunt present upper voltage range must be 2-3 V less than current register 'Shunt enable voltage' value !!!.**

<sup>2</sup> **Continuous operation:** The continuous torque provides the maximum possible load applied to the output shaft; exceeding this value will reduce the service life.

<sup>3</sup> **Intermittent operation:** The intermittent torque value may be applied for a short period. It should be for short intervals only and not exceed 25% of the continuous duty cycle.

<sup>4</sup> **Peak torque:** This torque limit represents the absolute maximum torque supported by the gearhead for unexpected events generated randomly on the output shaft load. Such peak torque cannot occur in cyclic mode or in a timely repetitive manner. This parameter is not intended to be used as a dimensioning constraint to drive any loads. Gearhead output is able to support such torque value with a non-repetitive scheme few hundreds to few thousand times during its operation without impacting service life.

## 2 PERFORMANCE DATA

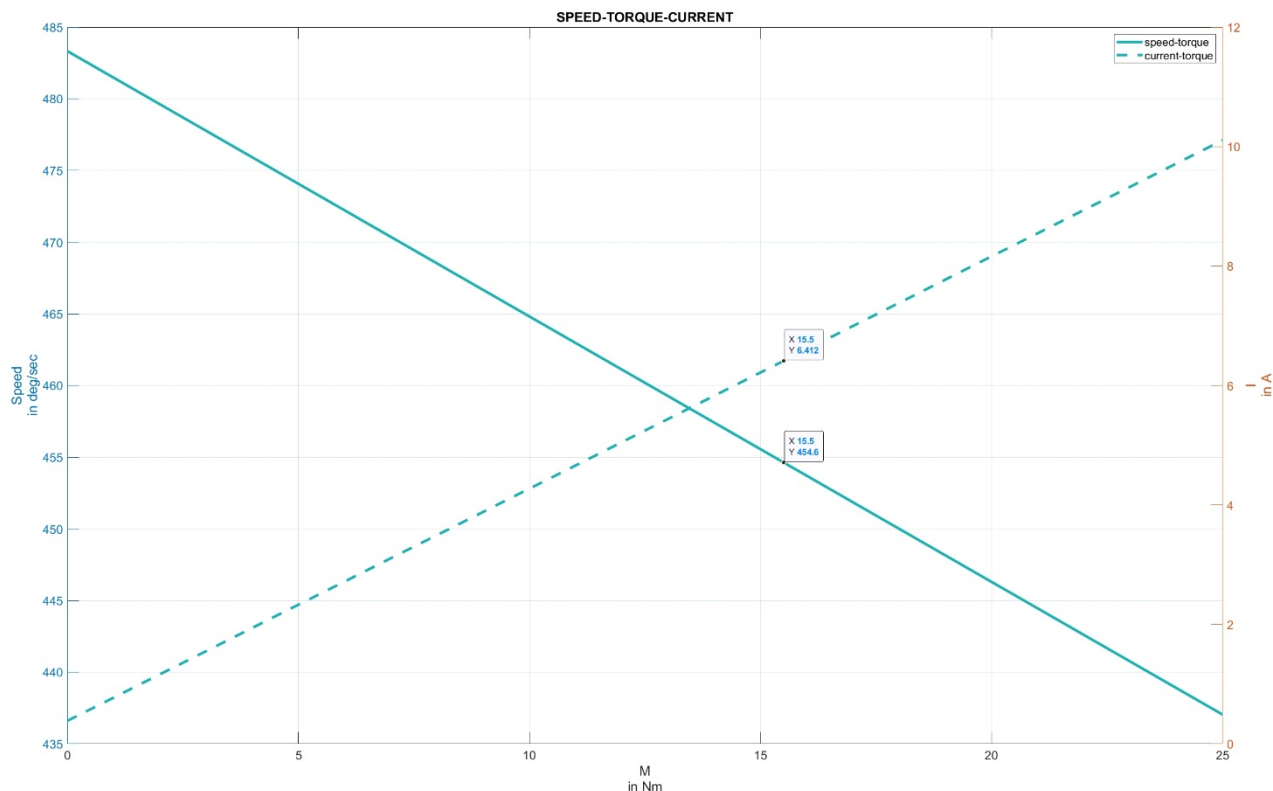

## 3 INTERFACE

#	INTERFACE DESCRIPTION	Comments	
1	Customization of RS-485 protocol for customer specific needs	Interface	RS485 half-duplex communication
		Baud rate	115200 bits per second (number of data bits – 8; number of stop bits – 1; parity - none)
		Max. frame rate	100 frames per second
		Programming Tool RS-485	UAVOS Servomotor Studio
		Communication Protocol	Custom ICD (Interface Control Data)

## 4 CONNECTION

Connect a cable with a mating connector Amphenol PT06E-14-12S to the product.

Assignment pin table

	Net	Description
A	CANL	L-signal bus CAN
B	CANH	H-signal bus CAN
C	RS422-Z (not used)	Not connected
D	RS422-Y (not used)	Not connected
E	RS422-B / RS485-B	Inverted signal RS485
F	RS422-A / RS485-A	Non-inverted signal RS485
G	Reserve	Reserve
H	Reserve	Reserve
J	Reserve	Reserve
K	GND	Supply Ground, Signal Ground
L	PE	Case Ground (Protective Earth)
M	+ V DC	Supply Voltage

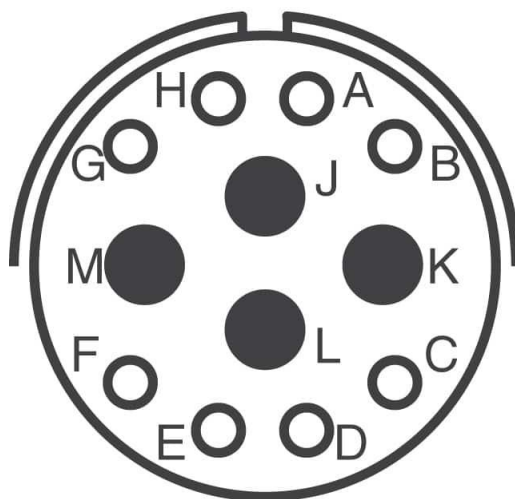

## 5 CATALOG NUMBER

